

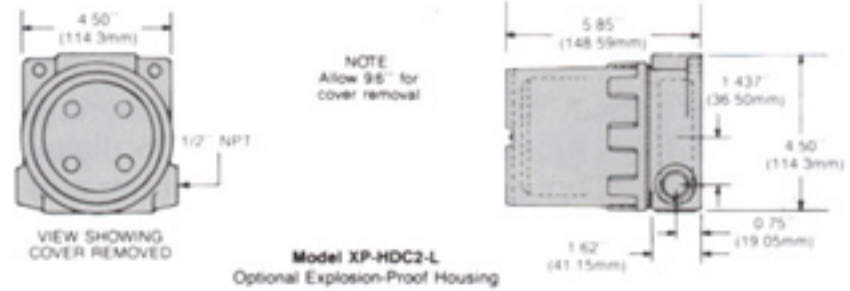

Physical Dimensions

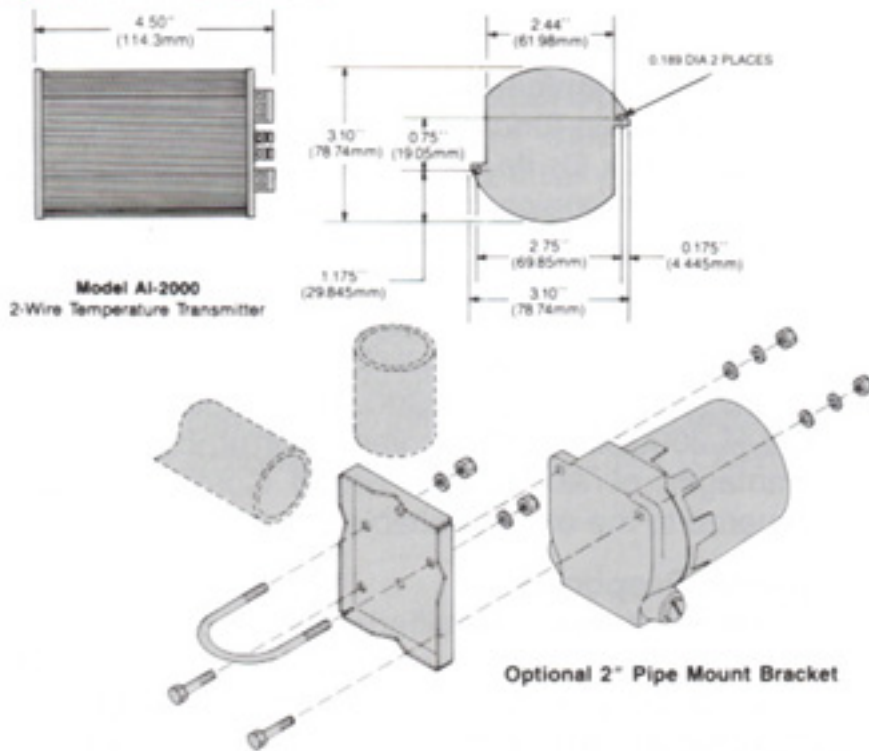

Connection Diagram

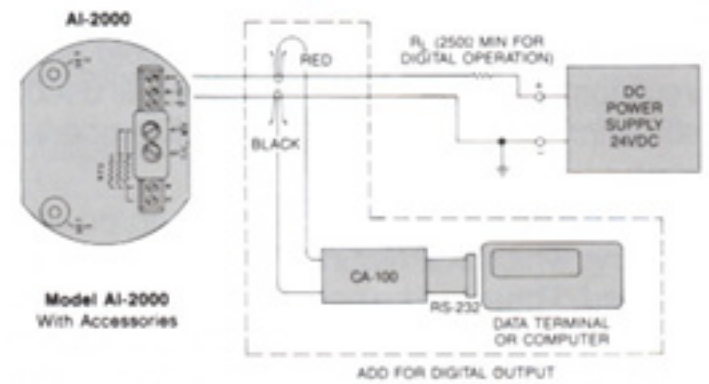

AI-2000, Revision 4 Specifications

Thermocouple Sensors: NBS Types B, E, J, K, N, R, S, T

RTD Resistance Sensors

100Ω Platinum DIN curve ($\alpha = 0.00385$).....	2-, 3-, or 4-Wire
100Ω Platinum NBS curve ($\alpha = 0.00392$).....	2-, 3-, or 4-Wire
120Ω Nickel.....	2-, 3-, or 4-Wire
10Ω Copper, consult factory.....	2-, 3-, or 4-Wire

Millivolt Input Range: -15 to 160 mV DC

Linearization: Thermocouple and RTD linearization to $\pm 0.05^\circ\text{C}$
Custom linearization user programmable at 21 points

Output: Analog, Two-wire 4 to 20 mA

Digital, Two-wire (RS-232, 300 baud with CA-100 adapter)

Output Ranging Adjustments

Analog Zero:	} 100% of sensor range—Noninteracting
Analog Full-scale:	
Digital Mode:	} Normal or Reverse Acting
	} $^\circ\text{C}$, $^\circ\text{F}$, $^\circ\text{K}$, $^\circ\text{R}$, mV (No ranging req)

Minimum Output Span: None

Output Resolution: Analog, 2.1 μA ; Digital, 0.01°, 0.001 mV

Transmitter Accuracy: Includes repeatability, hysteresis, load and ambient temperature effect. For a detailed analysis, refer to Accutech Application Note No. 203. Enhanced accuracy calibrations available from the factory.

Digital Output Accuracy: $\pm 0.04\%$ of the millivolt or ohm equivalent reading, or the accuracy from the table below, whichever is greater, plus the effect of a cold junction measurement error of $\pm 0.25^\circ\text{C}$ ($\pm 0.45^\circ\text{F}$) if using a thermocouple sensor.

Sensor	Digital Accuracy	Sensor	Digital Accuracy
B T/C	$\pm 0.8^\circ\text{C} \pm 1.44^\circ\text{F}$	S T/C	$\pm 0.6^\circ\text{C} \pm 1.08^\circ\text{F}$
E T/C	$\pm 0.2^\circ\text{C} \pm 0.36^\circ\text{F}$	T T/C	$\pm 0.2^\circ\text{C} \pm 0.36^\circ\text{F}$
J T/C	$\pm 0.2^\circ\text{C} \pm 0.36^\circ\text{F}$	Millivolt	± 0.008 mV
K T/C	$\pm 0.2^\circ\text{C} \pm 0.36^\circ\text{F}$	Pt RTD DIN	$\pm 0.1^\circ\text{C} \pm 0.18^\circ\text{F}$
N T/C	$\pm 0.2^\circ\text{C} \pm 0.36^\circ\text{F}$	Pt RTD NBS	$\pm 0.1^\circ\text{C} \pm 0.18^\circ\text{F}$
R T/C	$\pm 0.6^\circ\text{C} \pm 1.08^\circ\text{F}$	Ni RTD	$\pm 0.1^\circ\text{C} \pm 0.18^\circ\text{F}$

Reference Condition Accuracy: Equal to transmitter repeatability. When set up in the "Tap Mode," the transmitter is referenced to the prevailing conditions. Accuracy at this reference condition will include repeatability, linearity, cold junction, and hysteresis effects. If using a thermocouple, add 0.05°F for reference condition cold junction effect. ("Reference Condition Accuracy" is comparable in scope to that generally specified for analog-based signal conditioners.)

Analog Accuracy: Digital accuracy plus $\pm 4 \mu\text{A}$

Repeatability: One-half the respective accuracy

Dynamic Response

Turn-On Time: Less than 5 seconds after power-up

Ambient Temperature Gradient: Automatic compensation to $20^\circ\text{C}/\text{hour}$ change

Update Time: 0.15 second; Digital, 1 second

Response to Step Input: Analog; 0.25 second, typical Digital; 1 second, typical, to 95% of final value, 5 seconds, to stated accuracy

Cold Junction Compensation: Automatic correction to $\pm 0.25^\circ\text{C}$

Ambient Operating Temperature: -40 to $+167^\circ\text{F}$ (-40 to $+75^\circ\text{C}$)

Ambient Storage Temperature: -58 to $+185^\circ\text{F}$ (-50 to $+85^\circ\text{C}$)

Ambient Temperature Stability: Self-correcting over the operating temperature

Long-Term Stability: Less than 0.05% of reading plus $\pm 2.1 \mu\text{A}$ per year

Automatic Diagnostics: Every 3 seconds, self-checks for zero, span, cold junction, calibration references, malfunction, and sensor failure

Failsafe: Analog, user settable to 21 mA, 3.9 mA or "OFF" Digital, message or "OFF"

Interchangeability: All units interchangeable without field calibration

EM/RFI Immunity: Less than 0.5% of reading (SAMA PMC 33.1c test method) 20 kHz to 1000 MHz, 10 V/meter

Isolation: 850 VDC or peak AC

Common Mode Rejection: 120 dB

Reverse Polarity Protection: 42 VDC applied with either polarity

Power and Load: No load supply: 12 to 42 VDC

Supply Voltage Under Load:

$$V_{\text{SUPPLY}} = (12) + (R_{\text{LOAD}} \text{ in } \text{k}\Omega) \times (23 \text{ mA})$$

For Digital Operation, $R_{\text{LOAD}} = 250\Omega$ min.

Voltage Supply Effect: Digital, none; Analog, less than $\pm 0.005\%$ of span per volt.

Weight: 12 oz

Standard Configuration: Factory configured for J thermocouple, analog output, 40 to 200°F . Configuration can be user-performed in analog or digital mode. Custom factory configurations available to suit your requirements. See Price List.

Options: LD-2 Local Digital Display, KB-2 keyboard, CA-100 RS-232 Interface, HHT-420 Hand-Held Terminal, Explosion-Proof Housings, Sensors, Probes, and Thermowells. See Price List.

Ordering Information: Please order Model AI-2000. Specify any custom configuration, if desired. Order companion products as required.

AccutechTM
Smart Process Instrumentation

15 Bonazzoli Avenue • Riverside Industrial Park
Hudson, MA 01749 U.S.A. • TEL: (508) 568-0500
FAX: (508) 568-9085

Specifications subject to change without notice. Warranty: Adaptive Instruments Corporation warrants the 2000 series products to be free from defects in material, workmanship, and calibration under normal conditions of use and service, and will repair, replace, or recalibrate, free of charge, any component found to be defective, if returned to AIC with transportation prepaid, within two years of original purchase. See Warranty issued with product. Printed in USA. Copyright, 1995, AIC.