



Design Features

- High-quality chemical design
- Case, measuring system and medium-contacting parts from stainless steel
- Temperature detecting element diameter 6, 8 and ≥ 10 mm
- Different connections can be supplied
- Short immersion lengths may be used
- Accuracy class 1 / 2 per DIN 16196 range dependant
- Micro adjusting pointer for indication correction
- Mechanical or inductive contact device per DIN 19234

Application

These thermometers are suitable for use outdoors and in aggressive environments. Because of the robust design, these thermometers have been successfully used in the chemical industry, in petrochemistry, in ocean shipping, and in process engineering. The devices can also be supplied with additional liquid damping for use in extreme conditions. Further information on mounting these devices is to be found in data sheet no. T1-027. Suitable thermowells upon request.

Design and Function

The gas expansion thermometer with electric contact device consists mainly of a temperature detecting element with integrated pressure chamber (active part) and an indicating unit with bourdon tube and contact device tightly fixed onto it. The limit values can be adjusted over the complete scale range with the help of a wrench and are accessible from the front. Temperatures, which influence the indicating unit, are reduced with a compensation. Unless otherwise specified, the minimum immersion depth is the lower edge of the screwing.

Technical Data

Case
bayonet-ring case of stainless steel material no. 1.4301, nominal size 100 and 160 mm

Process connection
rigid temperature detecting element, radially protruding at bottom, alternatively centrally at rear.
Different connections can be supplied, see order details

Case design
degree of protection IP 66 per DIN 40050, liquid filling optional

Measuring element
bourdon tube dead zone free with noble gas filling

Temperature detecting element
stainless steel material no. 1.4404, diameter 6, 8 and ≥ 10 mm, can be supplied in standard lengths. Active lengths depend on temperature detecting element diameter, see order details, other values upon request

Movement
stainless steel with compensation

Scale
aluminium, white with black inscription. Alternatively with marking resp. fixed reference pointer

Pointer
aluminium, black with micro adjusting device for zero-point correction

Window
safety glass, alternatively macrolon with contact lock

Case seal
Buna N

Measuring system damping
liquid filling for damping vibrations

Nominal ranges
per EN 13190
max. -100...700 °C, measuring spans ≥ 60 °C

Accuracy
see under "switch function" and "connection diagram"

Ambient temperature
per EN 13190
ambient temperatures that deviate from EN are to be specified

Storage and transport temperature
per EN 13190
max. -20...+60 °C

Connection plug
waterproof terminal box with conduit thread cable entry and removable test cover, material macrolon

Weights
DN 100, without filling: approx. 1.1 kg
DN 100, with filling: approx. 2.0 kg
DN 160, without filling: approx. 2.0 kg
DN 160, with filling: approx. 4.3 kg

Special design
- design without screwing (D1001) also available with sliding screwing
- with construction type approval for connection to zone 0 with thermowells per DIN 43772
- with certification on material testing per EN 10204 (DIN 50049)

Instructions for use
the loading capacity of the temperature detecting element depends on the following parameters:
1. measured medium
2. measured medium pressure
3. measured medium temperature
4. flow velocity
5. immersion length
6. material
A technical test is necessary where required.

Information on other models upon request or see order details

Inductive contact devices

Insulating parts

duroplastic with high dielectric strength

Metal parts

corrosion-proof
nickel silver or stainless steel

Bearing

jewel hole, stainless steel axles,
smooth-running

EMC

per EN 60947-5-2, appendix x

initiators ¹	SJ2-N	SJ3.5 N	SJ3.5 SN
case diamter	100	160	160
PTB no.	Ex-83/2022X		
ex group	EEx ib IIC T6 or EEx ia IIC T6		
allowed ambient temperature for device	standard -25...+70 °C		
max. values U _o	in hazardous areas dependant on temperature class, values on request		
I _k	≤ 15.5 V		
P	≤ 50 mA		
self-inductance	30 uH	160 uH	160 uH
self-capacitance	20 nF	40 nF	40 nF

¹ other initiators upon request

Touch contacts

Allowed ambient temperature

-25...+70 °C (other values on request)

Metal parts

corrosion-proof
nickel silver or nickel-plated steel

Bearing

jewel hole; stainless steel axles,
smooth-running and wear resisting

Contact material

silver-nickel alloy (AG80Ni20) as standard assembly. For low voltages up to 24 V and currents up to 20 mA, we recommend silver palladium contacts with 10 µm gold plating, which are always delivered with ex-proofed models. Further contact materials upon request.

Devices, which switch signals below 24 V and 20 mA, should not be specified with liquid filling, because switching reliability is reduced by liquid films between the contacts. This applies to all contact materials.

max. contact load under resistive and inductive load and operation in air							
voltage per DIN IEC 38		slow acting contact			magnetic snap contact		
DC voltage	AC voltage	resistive load	inductive load	resistive load	inductive load	resistive load	inductive load
V	V	DC voltage	AC voltage	DC voltage	AC voltage	DC voltage	AC voltage
		mA	mA	cos φ > 0.7	cos φ > 0.7	mA	mA
220	230	40	45	25	100	120	65
110	110	80	90	45	200	240	130
48	48	120	170	70	300	450	200
24	24	200	350	100	400	600	250

limit values for the contact load under resistive load and operation in air (per DIN VDE 0660, section 100 and section 200)		
	slow acting contact	magnetic snap contact
rated insulation voltage U	61 - 300 V	61 - 300 V
rated voltage U _{eff} max.	250 V	250 V
rated current:		
making current	0.7 A	1.0 A
cutoff current	0.7 A	1.0 A
constant current	0.6 A	0.6 A
switching capacity	10 W 18 VA	30 W 50 VA

The use of contact protection relays is recommended in order to provide the greatest switching reliability possible, to prevent contact interruptions and to increase the breaking capacity. The service life of the contacts is considerably increased, because 99% of the time the contacts are opened and closed in a voltage-free state. This switching amplifier should definitely be used in measuring devices with liquid filling.

Dimensions

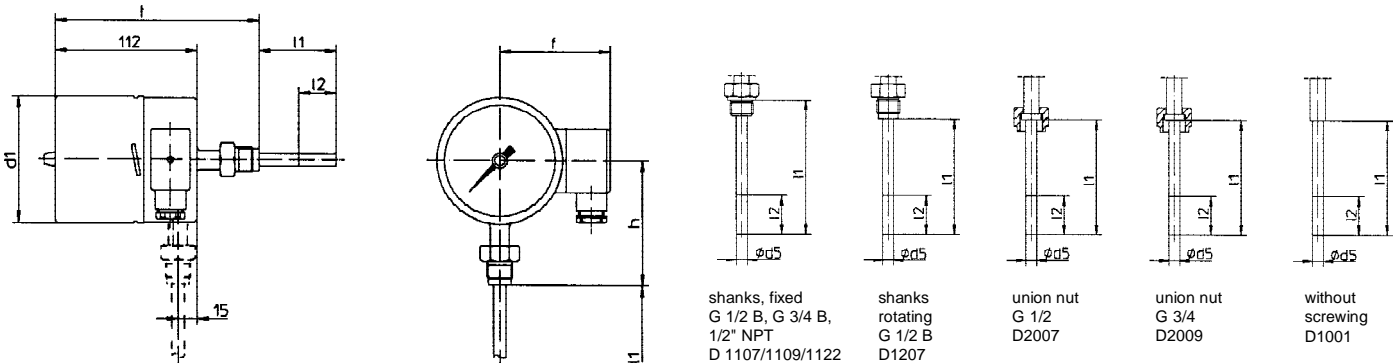

temperature detecting element diameter d5, immersion length l1 and active length l2 see order details

dimensions (mm)			h *						t *			
case	d1	f	D1001	D1107/1109/1122	D1207	D2007	D2009	D1001	D1107/1109/1122	D1207	D2007	D2009
DN 100	100	90	103	88	103	103	103	165	149	165	165	165
DN 160	160	120	133	118	133	133	133	165	149	165	165	165

* dimension increases by 40 mm for scale ranges > 160 °C

Switch function and connection diagram

Switch function, terminal connections and directions of effect are realized according to the DIN 16196. With regard to switches, it should be noted that a contact which closes with increasing temperature corresponds to a contact which opens with falling temperature. However, because of the switching hysteresis, they are adjusted differently.

Switch function and direction of effect

switching element	code number (order code)	direction of action	switch function	
			slow acting contact magnetic snap contact	inductive contact device
makers	1	increasing temperature	makes contact	makes contact; control current on
	4	decreasing temperature		
breakers	2	increasing temperature	breaks contact	breaks contact; control current off
	5	decreasing temperature		
change over elements ¹	3	increasing temperature	switches the contact	not applicable
	6	decreasing temperature		

¹ Unless otherwise specified, the contacts are not adjusted overlapping. Handle change over contact as double contact.

Connection diagram

contact device	switch function	assignment of connection terminals				
		slow acting and magnetic snap contact		inductive contact device		
		common supply	separate supply		polarity	
1st contact	makers	1	1	1	-	
		4	2	2	+	
	breakers	1	1	1	-	
		4	2	2	+	
	change over elements	makers	1	-	-	-
		breakers	4	-	-	-
2nd contact	makers	2	3	3	-	
		4	4	4	+	
	breakers	2	3	3	-	
		4	4	4	+	

Identification of the switch functions

The switch functions are clearly identified by a three-digit number key. The key must be specified in the order details.

The free positions in the number code for the single and double contact devices are each to be assigned a zero.

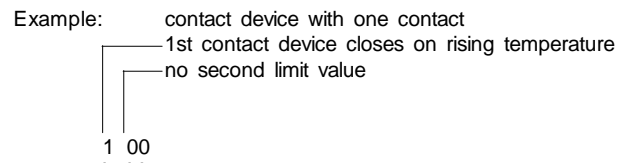
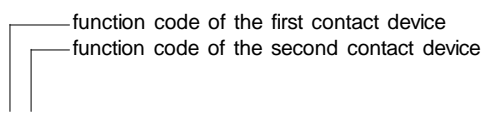

Connection plug / Connection diagram

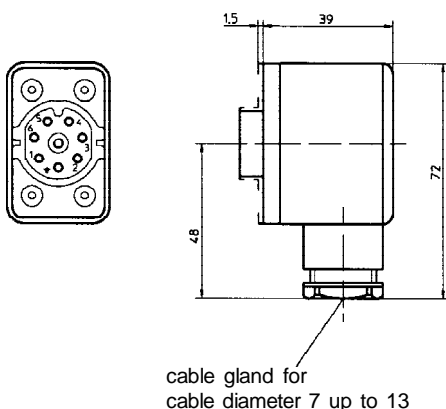

Accuracy ¹

nominal size	contact device	type of contact	
		inductive	touch contact
100	single	class 1	≤ class 2
	double	class 1	≤ class 2
160	single	class 2	class 2
	double	class 2	-

¹ specifications per EN 13190 / DIN 16196 for all temperature detecting diameters and standard immersion lengths l1

Order Details - please give additional specifications for models not listed -

Gas expansion thermometer with rigid bulb and electric contact device ¹ , high-quality chemical design										standard measuring and nominal ranges °C per EN 13190, class 1		
case	· DN 100					FU2				nominal range °C	meas. range °C	order code
	· DN 160					FU3						
case design	· IP 66 process connection bottom					40				-20...+40	-10...+30	340
	· IP 66 process connection at rear					30				-20...+60	-10...+50	346
	· IP 66 process connection bottom with filling					60				-30...+50	-20...+40	322
	· IP 66 process connection at rear with filling					50				-40...+40	-30...+30	220
design	· standard					0				-40...+60	-30...+50	222
	· ex-protection					1				0...60	10...50	520
measuring range	· per table					A2... ←				0...80	10...70	522
process connection	· shanks, fixed G 1/2 B					D1107				0...100	10...90	524
	· shanks, fixed G 3/4 B					D1109				0...120	20...100	540
	· shanks, fixed 1/2 NPT					D1122				0...160	20...140	544
	· shanks, rotating G 1/2 B					D1207				0...200	20...180	548
	· union nut G 1/2					D2007				0...250	30...220	560
	· union nut G 3/4					D2009				0...300	30...270	565
	· without screwing					D1001				0...400	50...350	627
temperature detecting element Ø d5	· 6 mm (l2 > 180 mm) ⁵					F6				0...500	50...450	630
	· 8 mm (l2 > 80 mm) ⁵					F8				0...600	100...500	640
	· 10 mm (l2 > 50 mm) ⁵					F10				0...700	100...600	650
immersion length l1 (mm) ⁶	D 11..	D1207	D2007	D2009	D1001							
	shanks fixed	shanks rotating G 1/2 B	union nut G 1/2	union nut G 3/4	without screwing							
	100	080	089	093	100						...	
	160	140	126	130	160						...	
	250	230	186	190	250						...	
	400	380	276	280	400						...	
deviating length: pls specify					999							
contact	<i>touch contact</i>											
	· combination contact with magnet ²											L4
	· combination contact with magnet, gold-plated											L1
	· slow acting contact ^{2/3}											L2
	· sep. circuit combination contact with magnet ²											M4
	· sep. circuit combination contact with magnet, gold-plated											M1
	<i>inductive contact</i>											
	· initiator (N)											N4
	· safety initiator (SN)											N1
· contact with integrated switching amplifier in 3-wire circuitry PNP ⁷											N6	
switch function ⁴	· single contact (1st figur per table)											.00 ←
	· double contact (1st and 2nd figure per table)											..0 ←
additional features (to be indicated in case of need, only)												
window	· macrolon											R11
marking	· on scale (pls specify)											T2
Order code (example):					FU2400	A2548	D1109	F8100	L4100			

nominal range °C	meas. range °C	order code
-20...+40	-10...+30	340
-20...+60	-10...+50	346
-30...+50	-20...+40	322
-40...+40	-30...+30	220
-40...+60	-30...+50	222
0...60	10...50	520
0...80	10...70	522
0...100	10...90	524
0...120	20...100	540
0...160	20...140	544
0...200	20...180	548
0...250	30...220	560
0...300	30...270	565
0...400	50...350	627
0...500	50...450	630
0...600	100...500	640
0...700	100...600	650

switch function	order code
· increasing temperature makes contact	1
· increasing temperature breaks contact	2
· decreasing temperature makes contact	4
· decreasing temperature breaks contact	5
· change-over elements increasing temperature switches ⁸	3
· change-over elements decreasing temperature switches ⁸	6

¹ gas expansion thermometer with pneumatic contact device upon request
² not with ex-protection
³ not for gauges with case filling
⁴ regarding accuracy pls see "switch function" and "connection diagram"
⁵ the active length l2 must completely reach the process temperature that is to be measured. The depth of immersion should be increased accordingly.
⁶ standard immersion length to be specified in order code, e.g. l1 100 mm: order code 100
⁷ further designs see data-sheet D6-039
⁸ only 1 change-over element possible; pls indicate switch point