

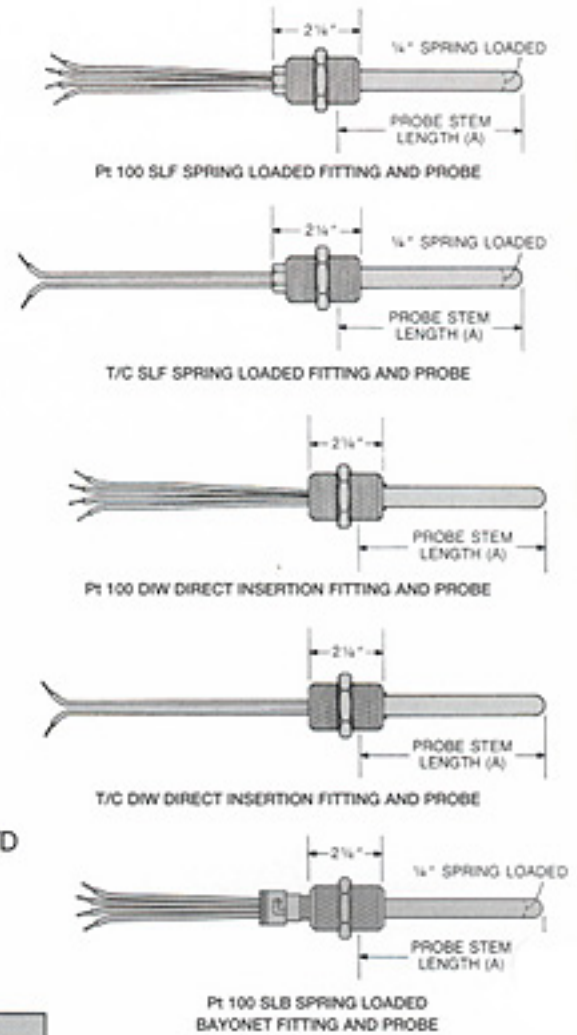

Order a temperature measurement system to include a sensor, thermowell, housing and transmitter. Sensors and thermowells may be ordered from the information below. Housings and transmitters may be ordered from the transmitter price lists or brochures. Sensors with the bayonet fitting may be installed with the weather proof head (WP-HEAD), or with the explosion-proof head (XP-HEAD).

INDUSTRIAL PROBE PART NUMBERS

PROB = INDUSTRIAL TEMPERATURE PROBE, 1/4" DIAM.

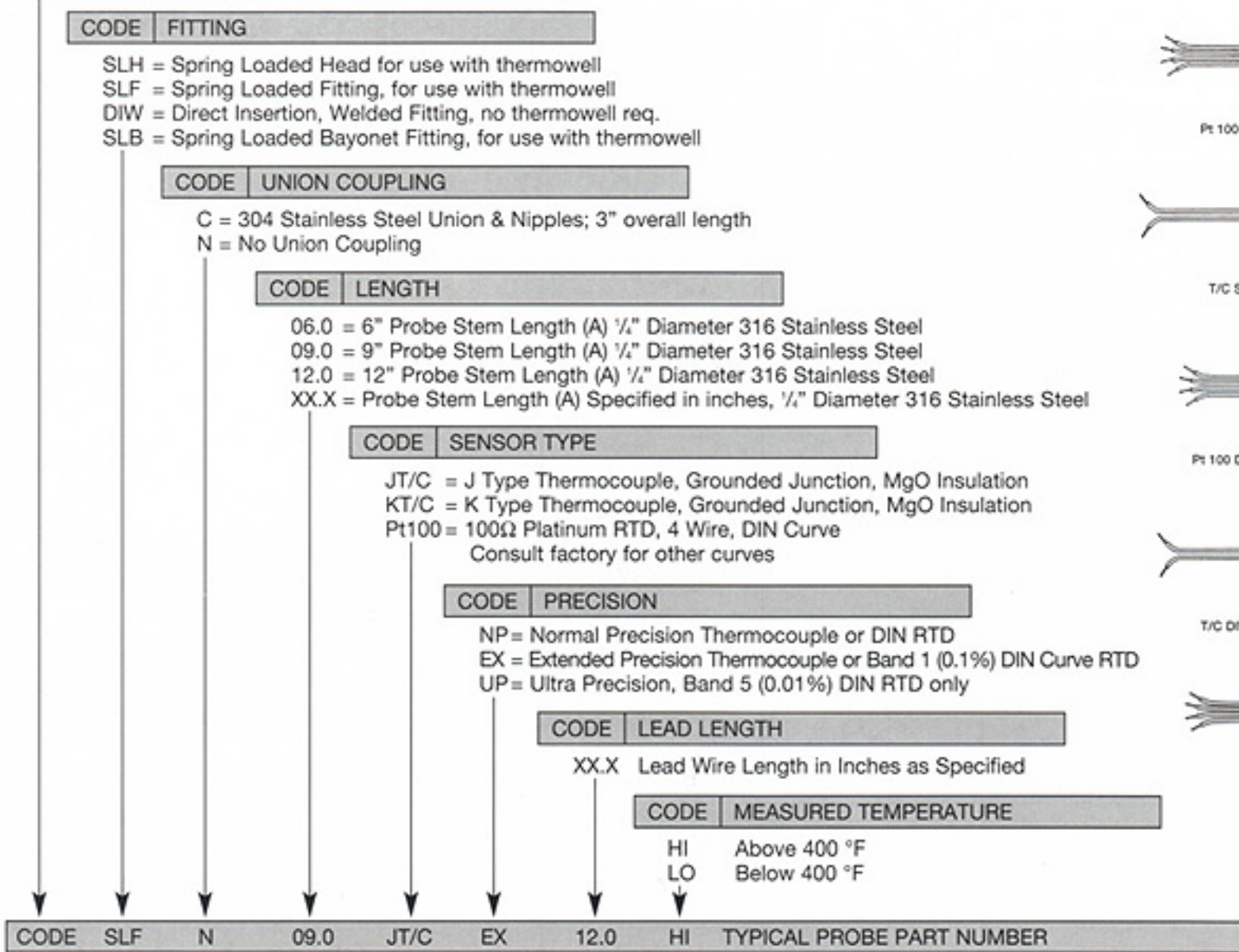

THERMOWELL PART NUMBERS

TWELL = THERMOWELL

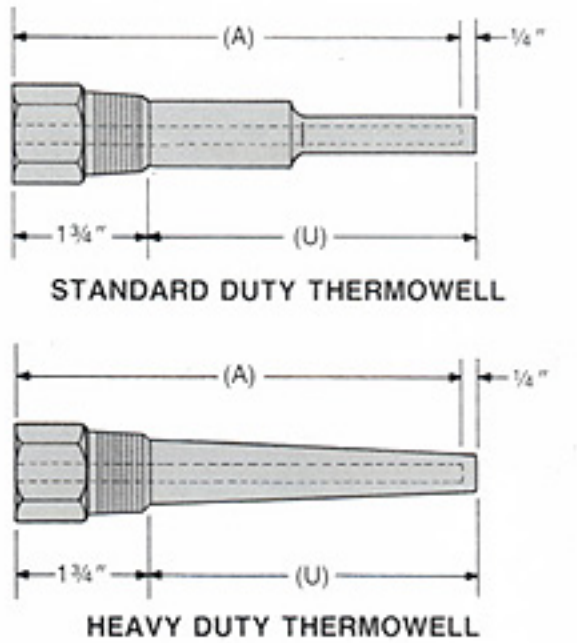
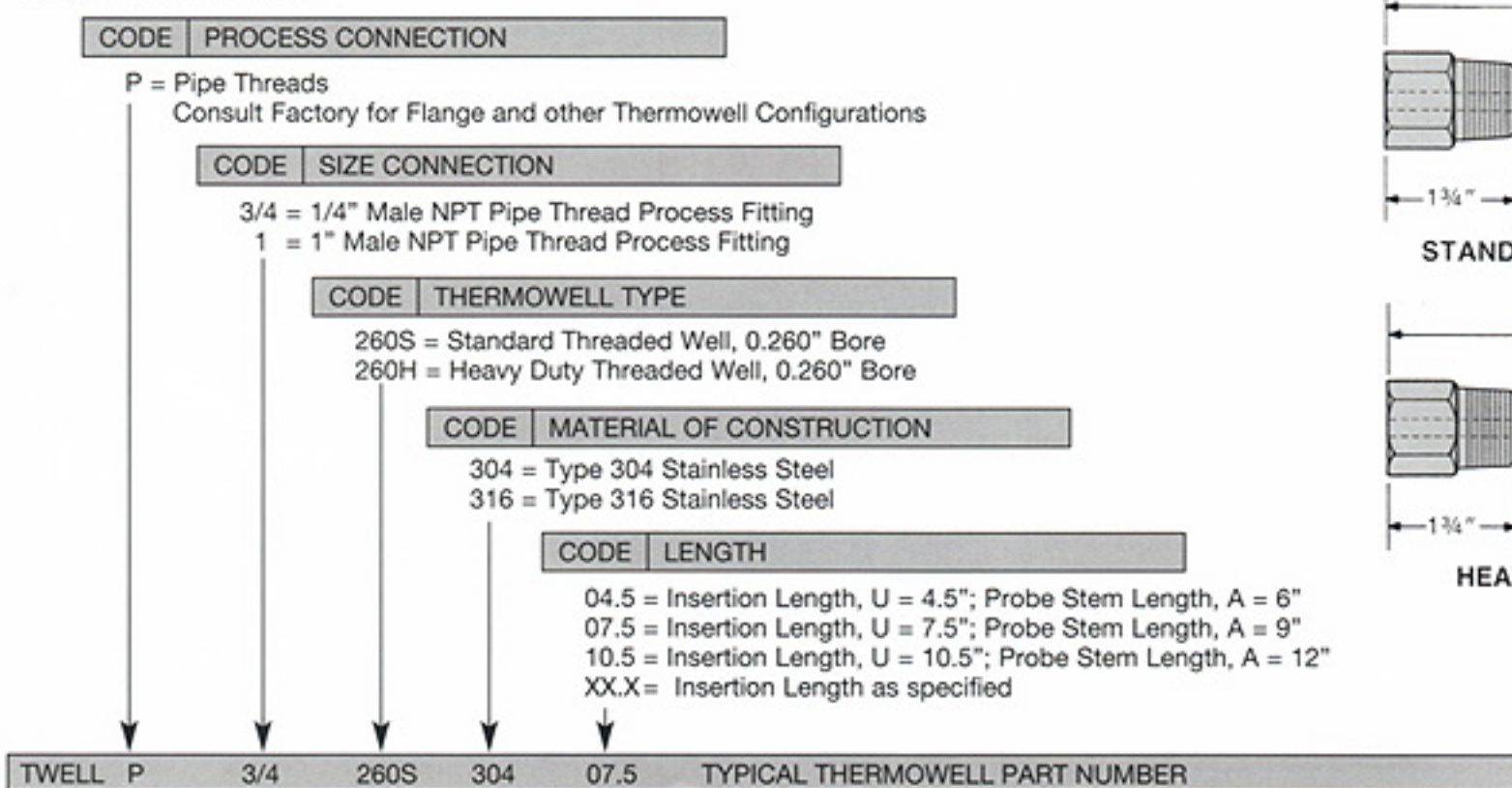

Consult factory for other configurations to meet your specific requirements



A Division of Adaptive Instruments Corporation
 577 Main Street • Hudson, MA 01749 U.S.A.
 TEL: 800-879-6576 (978) 568-0500 • FAX: (978) 568-9085
 email: accutech@adaptiveinstruments.com
 website: www.savewithaccutech.com

ISI CONTROL SDN. BHD.
 Industrial System Integrator (221401-V)
 The Level, Flow, Press, Temp & Analytical Specialist.
 7, Jalan USJ 9/5N, Subang Business Centre,
 47620 UEP Subang Jaya,
 Selangor Darul Ehsan, Malaysia
 Tel: 603-7244948 Fax: 603-7244211