

## DOPAK® Process Sampler Type DPM

system purge and continuous needle purge configuration

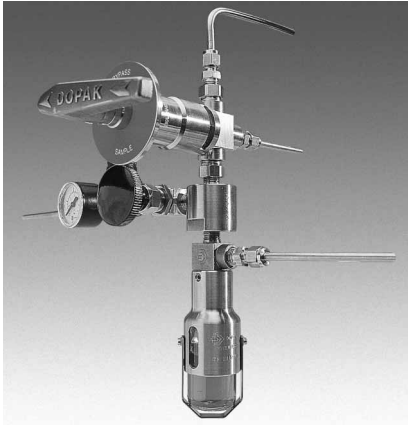

The ability to purge the sample point ensures optimal retrieval of a representative and contamination free sample.

The DPM type sampler in system purge configuration allows product to flow continuously through the sampler ensuring a fresh sample and also allows to purge the needle assembly continuously before and after sampling.

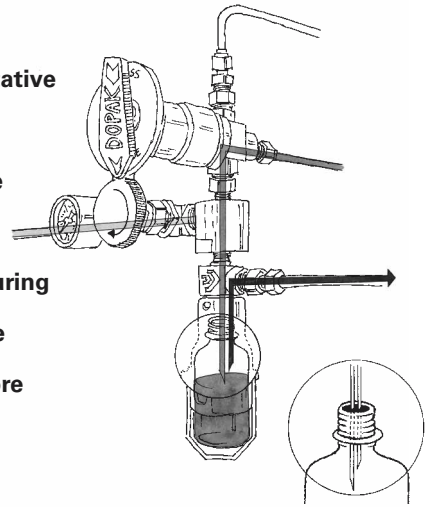

### 1 OPERATION/FUNCTION

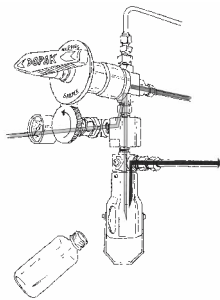

**0 - off**  
Provide a new septum on your sample bottle. Insert the bottle, with cap and septum into the sleeve until the septum is pierced by the needles. Put the bottle retaining clip in place. A flow of inert gas purges needle assembly and sample bottle continuously.

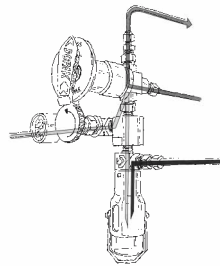

**1 - system purge**  
Turn the handle to the "system purge" position, allowing a continuous flow of liquid through the sampler to ensure representative sampling. This position can be held for any required time. A flow of inert gas purges needle assembly and sample bottle continuously.

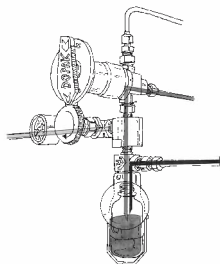

**2 - sample**  
Turn the handle to the "sample" position, allowing the product to flow into the sample bottle. When the required amount has been taken, turn the handle to the "off" position.

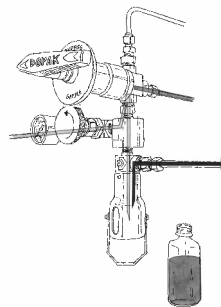

**3 - off**  
A flow of inert gas purges needle assembly and sample bottle continuously. Remove the bottle retaining clip and pull the bottle out of the sleeve. The septum reseals automatically.

### 2 TYPICAL P & ID

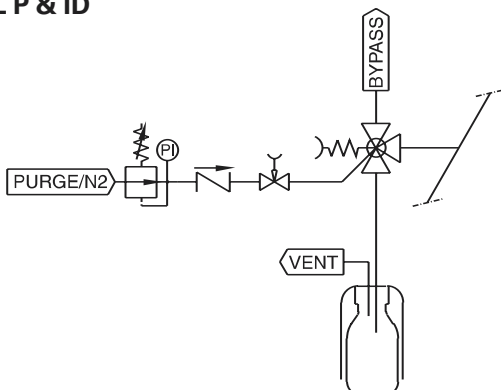

### 3 FEATURES/ADVANTAGES/PROPERTIES

- Sampling directly under process conditions
- Low pressure application
- Representative sampling
- Zero dead volume
- Closed sampling

### 4 BASIC SPECIFICATIONS

<b>Material</b>	SS316, SS316L.	
<b>Sleeve Type</b>	60cc sleeve with bottle retaining clip.	
<b>Needle Assembly</b>	Single piece VTO needle assembly with vent to outlet connection 1/4" FNPT. Process/vent needle ID: 1.35 mm.	
<b>Valve</b>	Three-way ball valve type W83. PTFE seats, Viton A O-rings. Pressure range 103 bar @ 20°C (1500 psig @ 70°F). Temperature range -17°C/+232°C (0°/+450°F).	
<b>Operation</b>	Manual.	
<b>Connections</b>	1/4" FNPT.	

**Please note:** the above is a basic specification only. Dopak Samplers can be offered with a wide variety of options as mentioned below.

### 5 OPTIONS

- |   |   |
|---|---|
| <input type="checkbox"/> Spring return handle | <input type="checkbox"/> Sample cooler              |
| <input type="checkbox"/> Lockable handle      | <input type="checkbox"/> Mounting bracket           |
| <input type="checkbox"/> Mounting plate       | <input type="checkbox"/> Steam sterilising cap      |
| <input type="checkbox"/> Pipe stand           | <input type="checkbox"/> Welded connection          |
| <input type="checkbox"/> Block valve          | <input type="checkbox"/> Exotic materials           |
| <input type="checkbox"/> Flow meter           | <input type="checkbox"/> Larger/smaller sample size |
| <input type="checkbox"/> Enclosure            |   |

For more information please refer to our sheets:

**Options for DOPAK® process sampler type DPM.**

**Components for DOPAK® process samplers.**

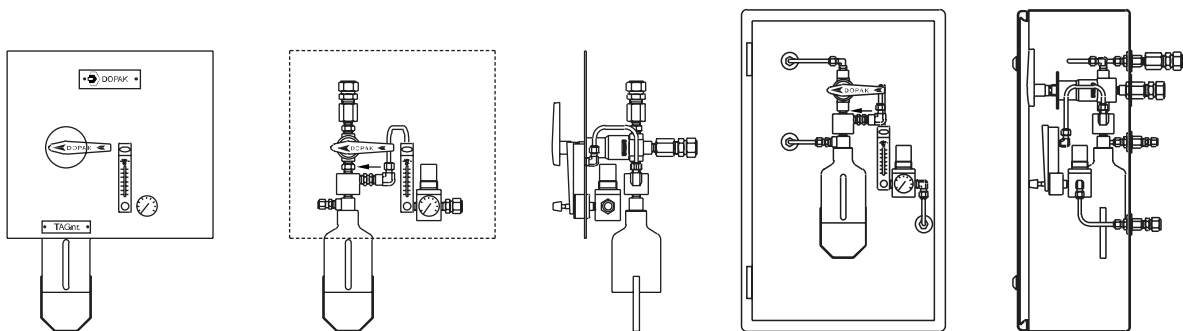

**Dopak Inc.**  
Houston, Texas 77080, USA  
Phone 713-460-8311  
Fax 713-460-8578  
E-mail info@dopak.com

**Dovianus BV**  
Rotterdam, The Netherlands  
Phone +31 10 420 60 11  
Fax +31 10 456 67 74  
E-mail info@dopak.nl

**Your local representative:**

