

DOPAK® Process Sampler Type DPM

back & needle purge configuration



The ability to back purge the sample point ensures optimal retrieval of a representative, contamination free sample. The needle purge ensures there is no residue or build up in the needle after sample retrieval.

The DPM type sampler in back & needle purge configuration allows purge gas to flow through the sampler ensuring a fresh sample and allows purging through the needle assembly.

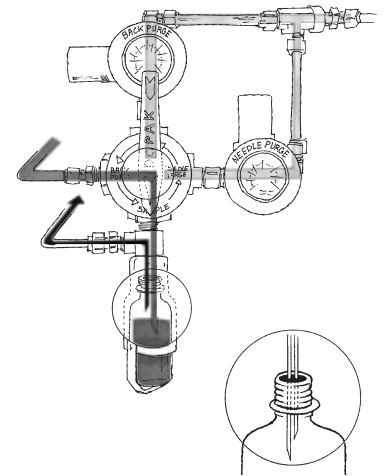

1 OPERATION/FUNCTION

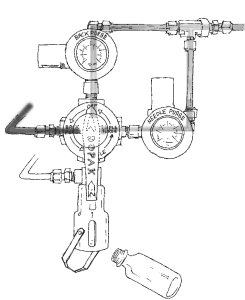

0 - off
Provide a new septum on your sample bottle. Insert the bottle, with cap and septum into the sleeve until the septum is pierced by the needles. Put the bottle retaining clip in place.

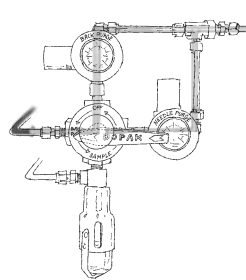

1 - back purge
Turn the handle to "back purge" position, allowing a flow of purge gas through the sampler to ensure representative sampling. This position can be held for any required time.

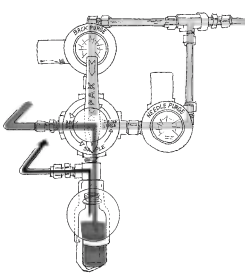

2 - sample
Turn the handle to the "sample" position, allowing the product to flow into the sample bottle. When the required amount has been taken, turn the handle to the "needle purge" position.

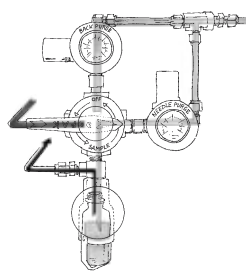

3 - needle purge
Turn the handle to the "needle purge" position, allowing a flow of purge gas through the sampler to ensure any residual liquid is forced into the sample bottle. This position can be held for any required time.

2 TYPICAL P & ID

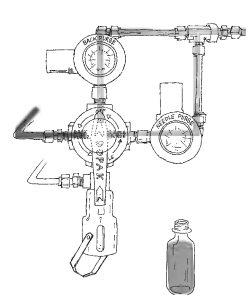
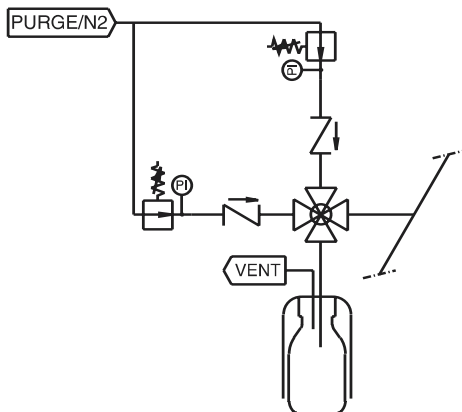

4 - off
Turn the handle to the "off" position. Remove the bottle retaining clip and pull the bottle out of the sleeve. The septum reseals automatically.



3 FEATURES/ADVANTAGES/PROPERTIES

- Sampling directly under process conditions
- Low pressure application
- Representative sampling
- Zero dead volume
- Closed sampling
- No build up of sample material in needle assembly
- Purging the sample bottle with an inert gas

4 BASIC SPECIFICATIONS

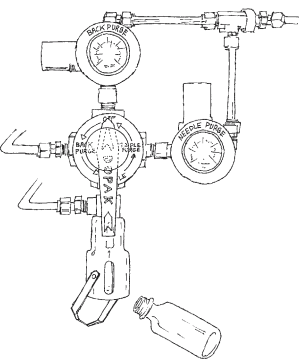
Material	SS316, SS316L.	
Sleeve Type	60cc sleeve with bottle retaining clip.	
Needle Assembly	Single piece VTO needle assembly with vent to outlet connection 1/4" FNPT. Process/vent needle ID:1.35 mm.	
Valve	Four-way ball valve. PTFE seats, PTFE coated Viton O-rings. Pressure range 103 bar @ 20°C (1500 psig @ 70°F). Temperature range -18/+179°C (0/+354°F).	
Operation	Manual.	
Connections	1/4" FNPT, regulator, gauge and check valve included.	

Please note: the above is a basic specification only. DOPAK® Samplers can be offered with a wide variety of options as mentioned below.

5 OPTIONS

- Spring return handle
- Lockable handle
- Mounting plate
- Pipe stand
- Block valve
- Flow meter
- Enclosure
- Sample cooler
- Mounting bracket
- Steam sterilising cap
- Welded connection
- Continuous needle purge
- Solvent purge
- Exotic materials
- Larger/smaller sample size

For more information please refer to our sheets:
Options for DOPAK® process sampler type DPM.
Components for DOPAK® process samplers.

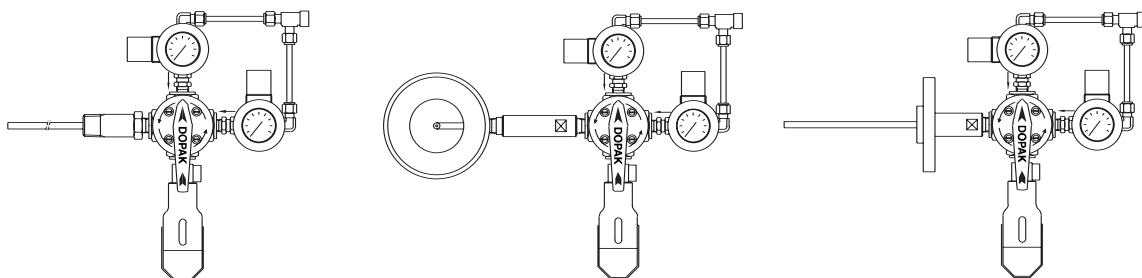

Dopak Inc.
Houston, Texas 77080, USA
Phone 713-460-8311
Fax 713-460-8578
E-mail info@dopak.com

Dovianus BV
Rotterdam, The Netherlands
Phone +31 10 420 60 11
Fax +31 10 456 67 74
E-mail info@dopak.nl

Your local representative: