

neptune[®] TYPE 4 FLOWMETER 3"



3" Type 4 with 800 Series Register.

Introduction

Actaris Neptune's 3" Compact flowmeters are superb instruments for metering petroleum products from large tank trucks where head loss must be kept to a minimum. This flowmeter comes complete with an air release valve, strainer, and Type 4 Auto-Stop valve. For pump operated systems where pressures exceed 50 psi, the 2" Type 1A valve is used. The basket type strainer can be removed from the top and cleaned quickly and easily without spilling product.

Non-Auto-Stop valve models with Model 831 and 833 registers are also available and are supplied with either a gooseneck outlet connection to prevent draining the flowmeter. To fit many piping arrangements, the inlet can be changed from left to right and the Auto-Stop or gooseneck can face several positions for each inlet setting. This adaptability saves piping, creates a neater arrangement, and is ideal for dual metering.

Specifications

Flow Rate

30 to 150 gpm (114 to 568 lpm).

Temperature

140°F (60°C) maximum.

Operating Pressure

125 psi (8.62 bar) maximum.

Direction of Flow

Standard Assembly has inlet at left, outlet to right. By repositioning the outlet valve or elbow adapter, by interchanging the outlet cap to reverse the air release, and by interchanging the air release and outlet valve, a large number of combinations is possible.

Connections

Inlet - flanged. Furnished with companion flange tapped for 3" standard pipe. Outlet - 3" female pipe for gooseneck or 2" Ansi flange for auto stop valve.

Units of Measure

Calibration in U.S. gallons, but Imperial gallons and litres can be provided on order where mechanism permits.

Reset Wheel Capacity

9,999.9 gallons on Direct Reading Registers.

Preset Setting Capacity

9,999.9 gallons on Models 832 (842) and 834 (844).

Printing Wheel Capacity

9,999.9 gallons on Models 833 (843) and 834 (844).

Totalizer Capacity

99,999,999 gallons - standard.

Materials

Casing - heat-treated aluminum.

Interior mechanism - corrosion-resistant metals.

Accessories

None required. Strainer and air release are assembled with the flowmeter.

ACCURACY CURVE

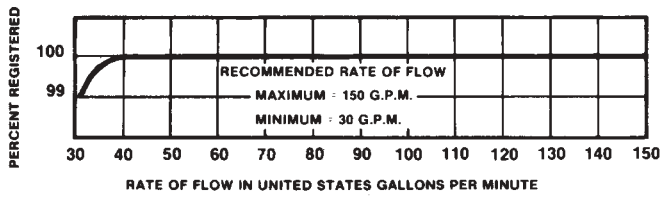

Part Number	Register Model Number	Type of Register	Weight Lbs. (Kgs.)
RP300114RGH2	834	Direct Reading Counter with Double-Trip Preset "Zero-Start" Printer and Totalizer	138
RP300114RLW2	(844)		(63)
RP300114RGC2	832	Direct Reading Reset Counter with Double-Trip Preset and Totalizer	134
RP300114RLM2	(842)		(61)
RP300114RGD0	833	Direct Reading Reset Counter with "Zero-Start" Printer and Totalizer	124
RP300114RLT0	(843)		(56)
RP300114RGA0	831	Direct Reading Reset Counter and Totalizer	120
RP300114RLL0	(841)		(54)

DIMENSIONS (Inches)

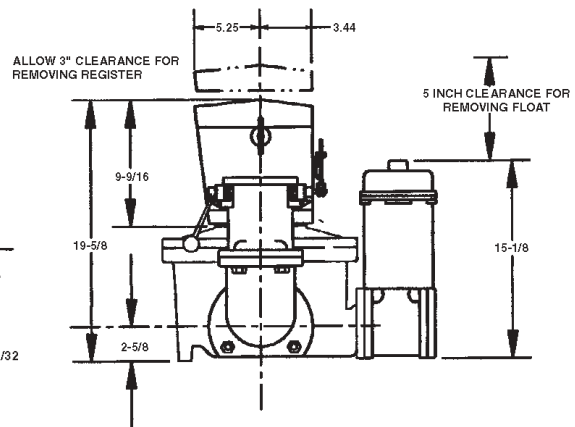
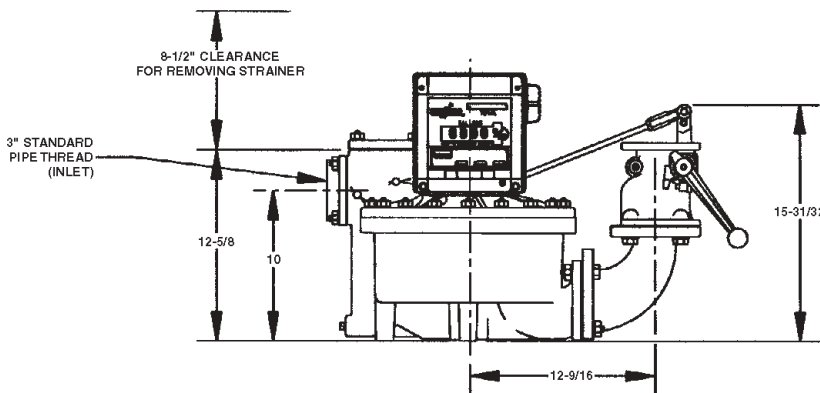
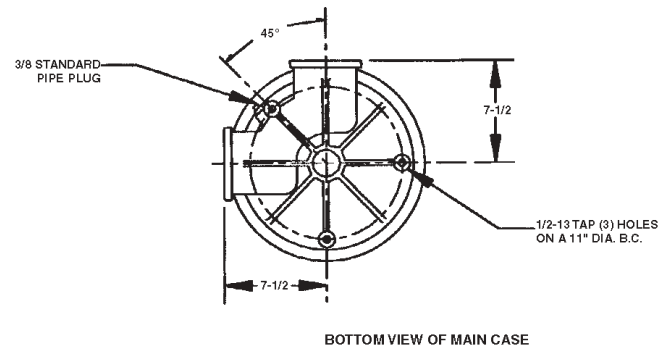
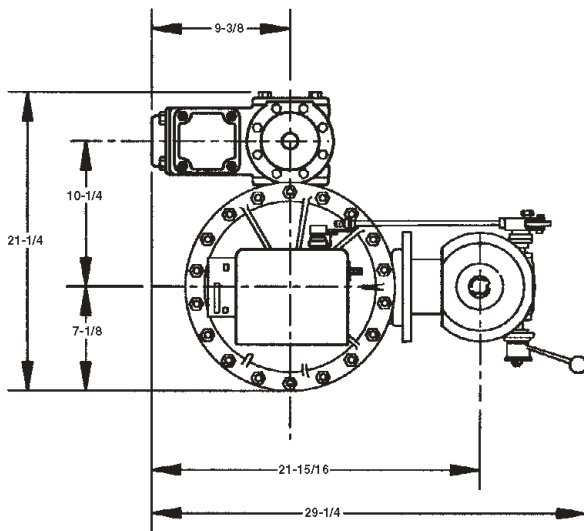

U.S.A./International:
 1310 Emerald Road
 Greenwood, SC 29646
 Tel.: Tol-Free (800) 833-3357
 (864) 223-1212
 Fax: (864) 223-0341

© 2002 Actaris Neptune Liquid Measurement Division 500 08/02

Specifications subject to change without prior notification.

