

MASStrol

Mass Flow Computer

Features

- Compensates Steam, Gases and Liquids for Temperature and Pressure to Yield Corrected Volume, Mass and Heat Flow.
- Two Line by 20 Character Super Twist Back-Lit LCD Display
- Square Root Extraction of DP Inputs
- 16 Point Linearization
- Displays Compensated Rate and Total Flow
- Takes a Direct 100 Ω Platinum RTD
- Flow Rate, Temperature and Pressure Alarms
- 4-20 mA and Pulse Output Based on Compensated Flow
- Non-volatile Memory
- 24 Volt Excitation Provided
- Front Panel NEMA 4X/IP 65 Rated



Description:

The KEP MASStrol is a microprocessor based instrument designed to measure compensated flow in an industrial environment. Three analog inputs for temperature, pressure and flow are provided to measure the parameters needed to calculate the actual compensated mass, volume or heat flow.

Special signal conditioning circuitry is included to allow direct connection of platinum resistance temperature detectors (RTD'S). A high speed digital input is provided to interface with pulse output type flowmeters. As an alternative, voltage inputs or current loops can be used for the above.

All instrument interface is with a 32 point screw terminal strip on the rear of the instrument.

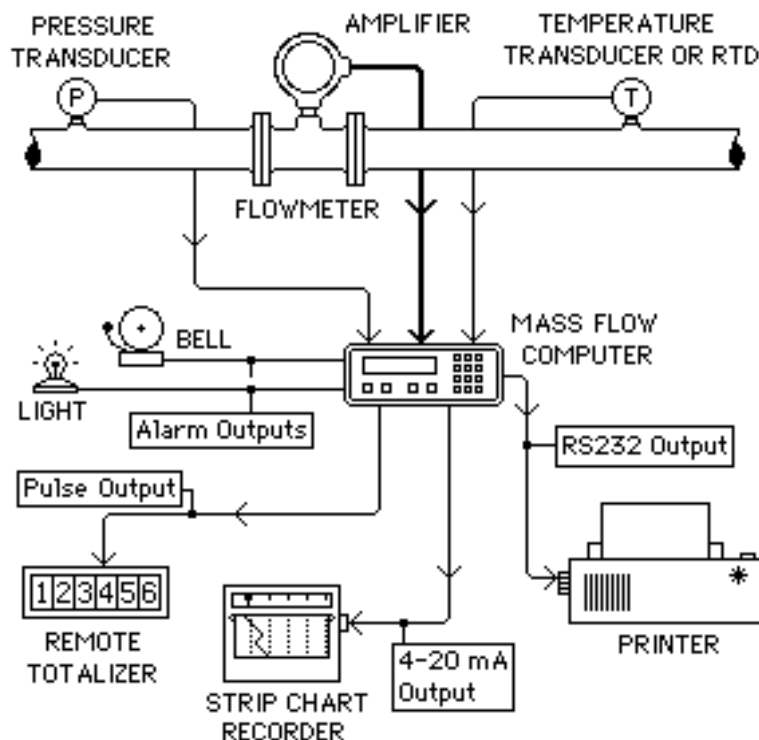

Flow Computer Application

- § Pressure transducer sends 0-5V signal to Flow Computer.
- § 100 Ω RTD direct hook-up to Flow Computer.
- § Turbine flowmeter sends digital signal to Flow Computer.
- § Flow Computer calculates flow and generates output signals.
- § 5 V pulse out to remote totalizer in supervisory area.
- § 4-20 mA out to strip chart recorder tracks trends.
- § RS232 out to printer for data logging.
- § Alarm relays activate bell and/or light as needed.

General Specifications:**OVERALL ACCURACY:** .25%**ENVIRONMENTAL:**Operating Temperature:
32° to 122° F (0° to 50° C)Storage Temperature:
-10 to 160 F (-23 to 71 C)

Humidity: 0 to 90% Noncondensing

Front Bezel: NEMA 4X/IP 65

Case: ABS Plastic

Approvals: CE Approved, UL/CSA Pending**POWER:** (Internally Fused)

Nominal Line Voltage: 100, 110, 220 or 240 VAC (50/60 Hz)

24VDC ±20% or 12VDC +20%/-10%

Power Consumption: 10 Watts max

Input Specifications:

The following applies to all inputs. Inputs are referenced to signal ground. All ground terminals are connected internally. NOTE: All inputs are single-ended with one leg grounded. The exception is the RTD input which is differential but is referenced to ground.

Transient protection: 100V 5nsec

ANALOG INPUTS:

Input Impedance: 100Ω

Range: 0-20mA, 4-20mA

Maximum sustained input voltage:

5 VDC (Fault Condition)

Resolution: ±.024% FS

VOLTAGE INPUTS:

Input Impedance: 115 kΩ

Range: 0-5V, 0-10V

Resolution: ±.024% FS

TEMPERATURE INPUTS:

Compatible RTD type: 100Ω Platinum

(α = .00385; DIN 43-760 Calibration)

Lead Wire Compensation: 4 Wire

Configuration: 2, 3 or 4 wire

Excitation Current: 2mA typical

Max Fault Current: 15mA

Max Volt on sense inputs: 50 VDC

Rejection of 50 or 60Hz signal: 40dB minimum (Automatically based on line frequency)

Raw Accuracy: ±.5°C

DIGITAL FLOW INPUT:

Range: 3-30 VDC Pulse

Max Input Frequency: 40kHz max

Min pulse width: 10μsec (with 40kHz filter)

Thresholds: OFF is less than 2.0V; ON is greater than 2.5V

Input Impedance: 40kΩ to ground.

Minimum Frequency to Maintain Rate Display: 5 Hz

Output Specifications:**ANALOG OUTPUT:**

Range: 4-20mA DC, sink only.

Compliance Voltage Range: 3.0 - 24 VDC

Load Type: Non Inductive

Accuracy: ±.5% FS

Update Rate: 1Hz

RELAY OUTPUTS:

One relay is a flow alarm output and a second is for other alarm conditions. Each has the following electrical specifications:

Type: Dry Contact, Form C

Contact Rating: 10A @ 115/230VAC/28VDC

AUXILIARY POWER OUTPUT: (AC powered units only)

Voltage: 24VDC regulated and filtered

Isolation: 230VAC max

Current: 0 to 100mA

Protection: Short Circuit Proof

The 24VDC Output is supplied with a resettable fuse.

DIGITAL FLOW PULSE OUTPUT:

This output is intended to drive a counter with a minimum input impedance of 1000Ω. It is compatible with TTL and 5V CMOS logic inputs. It is slew rate limited to help prevent RFI.

Output High Voltage:

No load: 4.5 Volts min

4.0 mA source: 4.0 Volts min

Output Low Voltage:

No Load: 0.2 Volts max

4.0 mA sink: 1.0 Volts max

Output waveform: Symmetric square wave above 1Hz

100msec pulse below 1Hz

Frequency Range: 0 to 50kHz

Max Slew Rate: 27 Volts/μsec

Sustained Fault Voltage for no permanent damage: 7 Volts

Transient Protection:

1500V @ 50μsec

RS232 COMMUNICATIONS:

Connector: 25 Pin Sub-D

Input Impedance: 3000Ω to 7000Ω

Compliance Voltage:

Output: -25 to -5 (Mark);

5 to 25 (Space); Volts

Input: -25 to -3 (Mark);

3 to 25 (Space); Volts

Protection: Short circuit proof.

Protocol: 8 bits, 1 Stop bit

Parity: None (Not monitored)

Available Baud Rates: 300, 1200, or 9600

DATA DISPLAY AND KEYPAD:

Internal 2 line by 20 character dot matrix, Backlit LCD display.

Sealed, 16 key panel featuring numeric keys

0- 9, plus the following keys:

A Advance through menus

B Back up through menus

C Cancel current menu selection

D Decimal point key

ENT General purpose enter or recall data key

CLR Data clear key

OPERATION:

Through the 16 button, NEMA 4X/IP 65, front keypad, the operator enters all parameters necessary to configure the mass flow computer. One MASStrol will handle all of your mass flow requirements.

The type of flow equations desired (steam tables, ideal gas law or liquids) must be selected first. For steam flow and heat measurement, the 1967 ASME steam tables for both saturated and superheated steam are stored in memory. For gases, the ideal gas law is used. For liquids and heat calculations, factors are entered through the front keypad.

Additionally, the following hardware parameters must be entered to configure the MASStrol input signal types (from the flow, temperature and pressure transmitters) along with their corresponding ranges or K factors; alarm set points may be entered; the output range for the 4-20 mA signal and the pulse output scaling factor. The operator can select, in any order, up to 16 parameters to display on the read out.

If it is so desired, the operator then can lockout the unit from changes by entering a five digit lockout code.

Optional RS232 serial communications for ease of programming and timely printouts of flow results and/or parameters is available. If RS232 two way communications and the keypad are being used simultaneously, the serial port takes precedence.

SOFTWARE ACCESSORIES:

K1 Diskette:

A diskette program is available to assist in the computation of the K1 term. The K1 factor is used in Orifice/Pitot/Annubar calculations. The K1 factor is the calibration factor for the meter run. It is part of the Variables menu for flow input values (analog).

MASSCON Diskette:

The MASSCON diskette program facilitates the configuration and calibration of the flow computer. The program runs on PC compatibles and communicates through the RS232 port.

FLOW CALCULATIONS:

DEFINITION OF TERMS

TREF: Base Reference Temperature entered by user.

C: Thermal coefficient of expansion for the liquid media ($\times 10^{-6}$).

DENSITY: Density as calculated from parameters and inputs.

DP: Differential pressure calculated from flow input in inches of water or millimeters of water.

Hz: Input frequency in cycles per second.

K: The meter calibration factor in pulses per ft³, gal, M³ or liter

K1: Orifice/Pitot/Annubar Calibration Factor

MASS: Mass flow rate from calculations using temperature, pressure and flow. Del Heat equation uses temp1 for mass calculations.

PSIA: The absolute pressure (Gage pressure + Barometric pressure).

PSIG: Upstream gage pressure calculated from input.

SG: Specific Gravity as entered by user with respect to Standard conditions or the Base Reference temperature

SH: Specific Heat as entered by user or from Steam Tables.

TEMP: Temperature as calculated from input.

UCFLOW: Uncompensated flow as determined by calculations.

VOL: Corrected Volumetric Flow as determined by calculations.

Z: Mean Gas compressibility factor as entered by user.

%: Input signal as percentage of span

SVOL: Specific Volume at operating pressure and temperature.
English = ft³/lb Metric = M³/Kg

INPUT CALCULATIONS

Temperature: $\text{temp lo} + [(\text{temp hi} - \text{temp lo}) \times (\%)] = \text{Tf}$

Pressure: $\text{press lo} + [(\text{press hi} - \text{press lo}) \times (\%)] = \text{Pf}$

Analog-Orifice/Pitot: $\Delta P \text{ lo} + [(\Delta P \text{ hi} - \Delta P \text{ lo}) \times (\%)] = \text{DP}$

DENSITY CALCULATIONS

Density-Liquid (liquid volume eq):
 $\text{SG} \times \text{DENSITY H}_2\text{O} \times [1 - (\text{C} \times 1.0 \times 10^{-6} \times (\text{Tf} - \text{Tref}))] = \text{DENSITY}$

Density-Liquid (liquid mass eq):
 $\text{SG} \times \text{DENSITY H}_2\text{O} \times [1 - (\text{C} \times 1.0 \times 10^{-6} \times (\text{Tf} - \text{Tref}))]^2 = \text{DENSITY}$

Density-Steam: $1/\text{SVOL} = \text{DENSITY}$

Density-Gas English:
 $(2.698825 \times \text{SG} \times \text{PSIA}) / (\text{Z} \times \text{TEMP} + 459.67) = \text{DENSITY}$

Density-Gas Metric:
 $(3.483407 \times \text{SG} \times \text{kPa}) / (\text{Z} \times \text{TEMP} + 273.15) = \text{DENSITY}$

UNCORRECTED VOLUME FLOW CALCULATIONS

Digital: $(\text{Hz}/\text{K}) \times (60 \text{ sec}/1 \text{ min}) = \text{UCFLOW}$

Analog-Linear: $\text{Lo Flow} + [(\text{Hi Flow} - \text{Lo Flow}) \times (\%)] = \text{UCFLOW}$

Orifice/Pitot Calculation English:
 $\text{K1} \times \sqrt{\text{DP}/(\text{DENSITY} \times 0.3705316202)} = \text{UCFLOW}$ (in ACFM)

CORRECTED VOLUME FLOW CALCULATIONS

Gas English:
 $(\text{PSIA}/14.696) \times (519.67/\text{TEMP} + 459.67) \times (1/\text{Z}) \times \text{UCFLOW} = \text{VOL}$
Where reference conditions = 60°F, 14.696 PSIA

Gas Metric:
 $(\text{KPa}/101.329) \times (273.15/\text{TEMP} + 273.15) \times (1/\text{Z}) \times \text{UCFLOW} = \text{VOL}$
Where reference conditions = 0°C, 101.325 KPA

Liquid:
 $\text{UCFLOW} \times [1 - \text{C} \times (\text{Tf} - \text{Tref})] = \text{VOL}$

MASS FLOW CALCULATIONS

$\text{UCFLOW} \times \text{DENSITY} = \text{MASS}$

HEAT FLOW CALCULATIONS

Gas/Liquid English:
 $\text{MASS} \times \text{SH} \times (\text{TEMP} + 459.67) = \text{HEAT}$

Gas/Liquid Metric:
 $\text{MASS} \times \text{SH} \times (\text{TEMP} + 273.15) = \text{HEAT}$

Steam:
Specific Enthalpy $\times \text{MASS} = \text{HEAT}$

Del Heat Liquid:
 $\text{MASS} \times \text{SH} \times (\text{TEMP1} - \text{TEMP2}) = \text{HEAT}$

TERMINAL BLOCK DESIGNATIONS:

	RTD	VOLTAGE IN	CURRENT IN	FUNCTION
1	RTD EXCITATION +	-----	-----	CHANNEL 1 TEMPERATURE
2	RTD SENSE +	-----	-----	
3	RTD SENSE -	-----	-----	
4	RTD EXCITATION -	-----	I IN +	
5	GROUND (SHIELD)	V IN - (GND)	I IN - (GND)	
6	-----	V IN +	-----	
7	RTD EXCITATION +	-----	-----	CHANNEL 2 PRESSURE or AUX. TEMP.
8	RTD SENSE +	-----	-----	
9	RTD SENSE -	-----	-----	
10	RTD EXCITATION -	-----	I IN +	
11	GROUND (SHIELD)	V IN - (GND)	I IN - (GND)	
12	-----	V IN +	-----	
13	-----	-----	I IN +	CHANNEL 3 FLOW ANALOG INPUT
14	GROUND (SHIELD)	V IN - (GND)	I IN - (GND)	
15	-----	V IN +	-----	
16	EXCITATION VOLTAGE (5.6K PULL-UP TO 5VDC)			CHANNEL 3 FLOW PULSE INPUT
17	PULSE INPUT (3-30VDC)			
18	GROUND (SHIELD)			
19	ANALOG OUTPUT (SINK)			ANALOG OUT
20	PULSE OUTPUT			5V SCALED PULSE OUT
21	GROUND (SHIELD)			
22	N.O.			ALARM RELAY
23	N.C.			
24	COMMON			
25	N.O.			FLOW ALARM RELAY
26	N.C.			
27	COMMON			
28	115/230 VAC 50/60Hz			POWER (AC)
29	115/230 VAC 50/60Hz			
30	+24 VOLTS	24VDC OUT	+ VDC IN	POWER (DC) (DC POWERED UNITS ONLY)
31	24 VOLTS RETURN	(AC POWERED UNITS ONLY)	-DC (GND)	
32	CHASSIS GROUND			

TYPICAL HOOKUP:

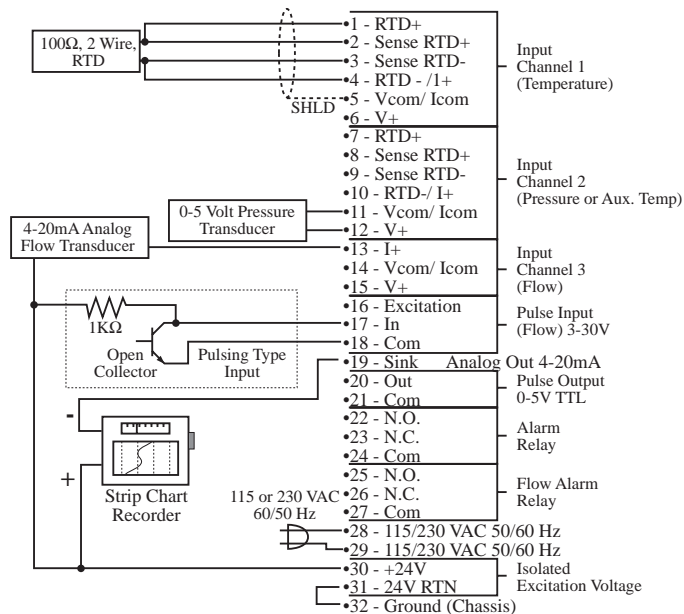

Ordering Information

Example: MFC A 1 BL

Series: MFC

Operating Voltage:

- A: 115 VAC ± 15% at 50/60Hz
- B: 230 VAC ± 15% at 50/60Hz
- C: 24 VDC ± 20%
- D: 12 VDC -10, +20%

Options:

- 1: RS-232 Serial Interface
- CSA: CSA Approved Unit (pending) (consult factory)

Display:

- BL: Backlit Display (standard)

Accessories:

NEMATROL 4X1 - NEMA 4X/IP 65 Enclosure for wall mounting accommodating 1 TROL Series unit.

NEMATROL 4X2 - NEMA 4X/IP 65 Enclosure for wall mounting accommodating 2 TROL Series unit.

FLEXCOVER #36120

XTROL7/4- Explosion proof housing

Dimensions:

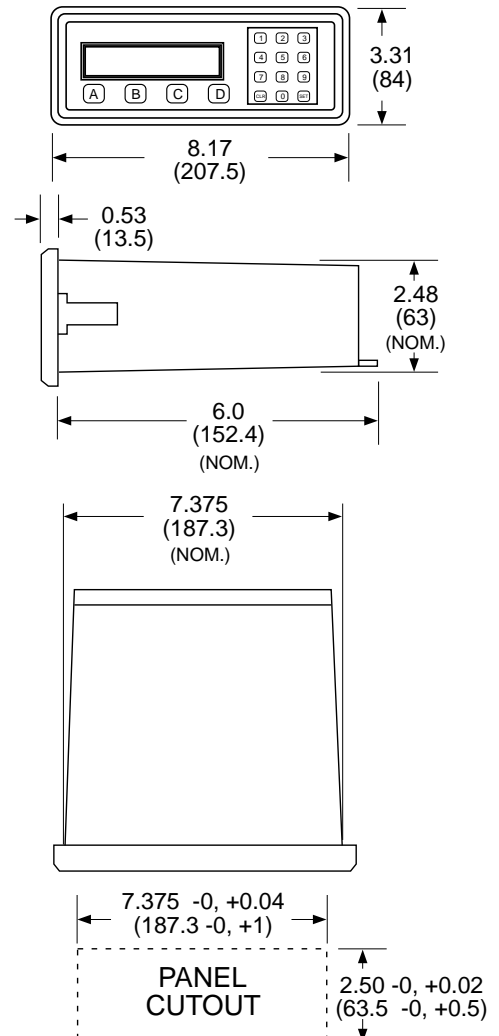

Flow Instruments
FLOW COMPUTERS