

Duo Steam Traps BK

Thermostatic steam traps with Duo stainless steel (bimetallic) regulator
Pressure ratings up to PN 630.

For roughest operating conditions.
Unexcelled service life.

Operating principle resulting in a sturdy design unaffected by waterhammer and frost.

May also be used as air vents.

Operation

Opening and closing are controlled by the temperature sensor of Duo stainless steel plates and the stage nozzle operating together. During start-up of the plant and in the presence of cold condensate and air the Duo stainless steel plates are flat. The service pressure acts in the opening direction, the valve is completely open.



With rising condensate temperature the plates deflect and draw the stage nozzle towards the closed position (a thermostatic process). The service pressure and the pressure built up in the stage-nozzle chamber by flashing produce an opposite force (a thermodynamic process). The orifice area is determined by the prevailing state of equilibrium between the temperature-dependent closing force and the pressure-related opening force.



Immediately below saturation temperature (boiling temperature) the plates are deflected to such an extent that the stage nozzle is almost closed. As a consequence the pressure in the stage-nozzle chamber decreases and breaks down as the flashing across the stage nozzle then closes. The deflection of the Duo stainless steel plates created by the temperature is not sufficient to produce, over the complete pressure range, the force required to counteract the force acting on the stage nozzle in the opening direction. The plates are therefore arranged in a stack which acts as a spring having a characteristic that adapts itself to the force acting on the stage nozzle varying with the service pressure. Thermostatic and spring characteristics are balanced so that the opening and closing temperatures are always just a few degrees below saturation temperature.



Rhombus-shaped cover ▶
 secured with only two bolts,
 which are easy to insert and
 easy to use in restricted spaces.

**Temperature feeler of Duo
 stainless steel plates** ▶
 Thermostatic control.
 Corrosion-resistant
 throughout, fatigue-free,
 not subject to ageing.

Thermovit regulator ▶
 Light and compact regulator
 unit, replaceable without
 removing body from pipeline.
 Withstands waterhammer and
 freezing. Easy maintenance.

Stage nozzle ▶
 Thermodynamic control.
 Wear resistant. Freely mounted
 for non-return valve action.

Large-surface strainer ▶

▶ **Recessed flat gasket for
 superior sealing**

▶ **Metal base bushing**

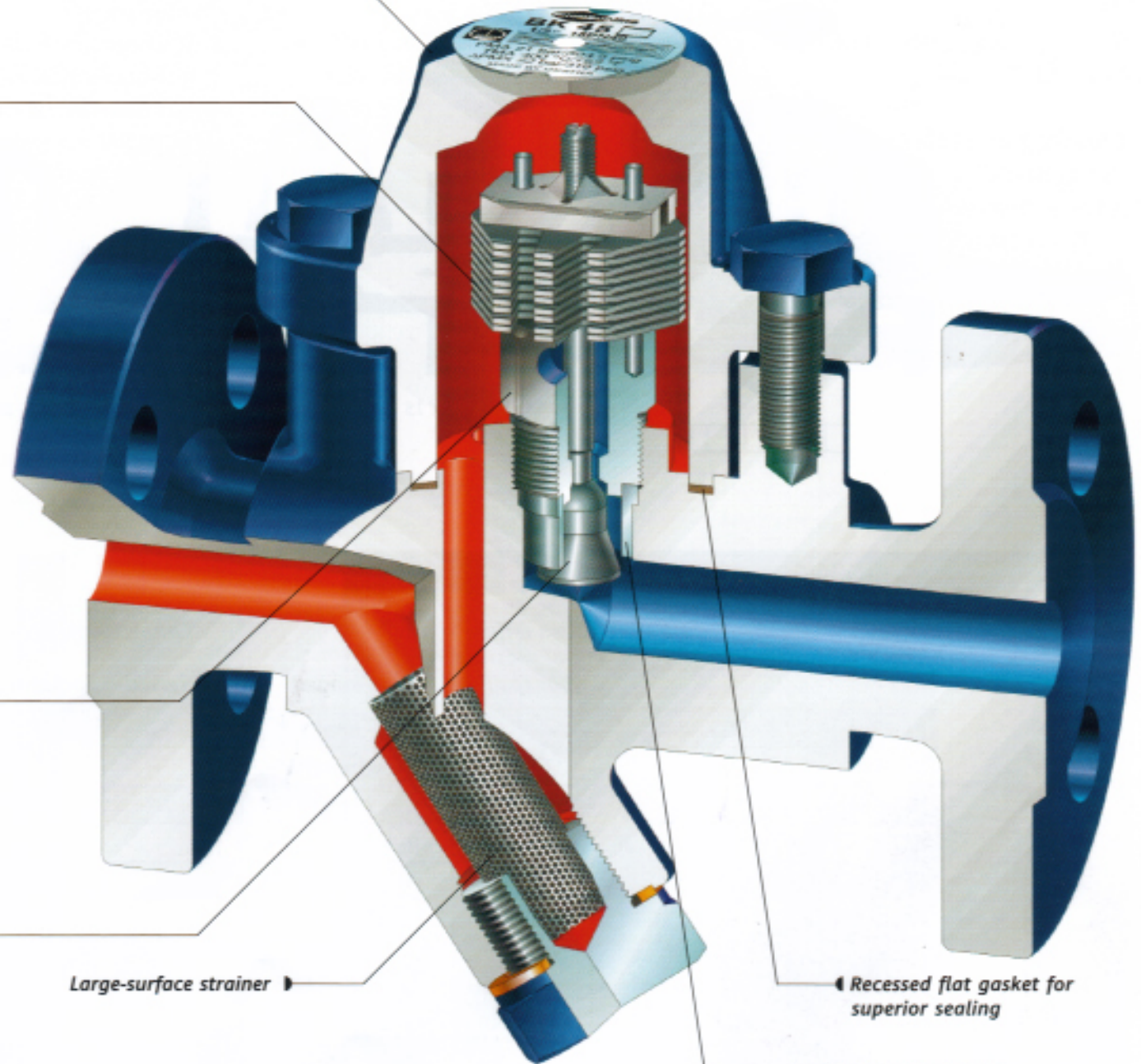

BK Types and Connections

RHOMBUSline®



BK 45
BK 46

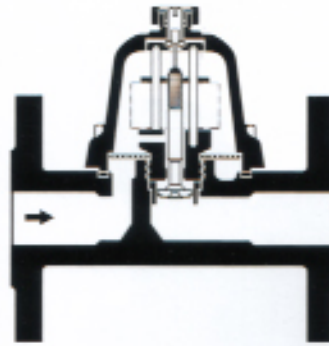

BK 15

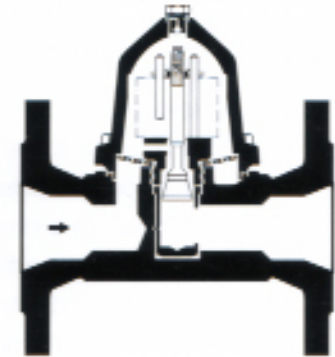

BK 27

The BK traps at a glance

| Type | Material | Max. differential pressure bar (psi) | Connections, DN | | | |
|-------------|--------------------------------|---|----------------------|---------|-------------|----------------------|
| | | | Flanged | Screwed | Socket-weld | Butt-weld |
| BK 45 | C 22.8 | 22 (320) | 15–25 mm (1/2"–1") | 1/2"–1" | 1/2"–1" | 15–25 mm (1/2"–1") |
| BK 15 | C 22.8 | 22 (465) | 40–50 mm (1 1/2"–2") | | 1 1/2"–2" | 40–50 mm (1 1/2"–2") |
| BK 46 | 15 Mo 3 | 32 (580) | 15–25 mm (1/2"–1") | 1 1/2" | 1 1/2" | |
| BK 27 | 15 Mo 3 | 45 (650) | 40–50 mm (1 1/2"–2") | | 1 1/2"–2" | 40–50 mm (1 1/2"–2") |
| BK 28 | 15 Mo 3 | 85 (1230) | 15–25 mm (1/2"–1") | | 1/2"–1" | 15–25 mm (1/2"–1") |
| BK 29 | 13 CrMo 44 | 110 (1600) | 15–25 mm (1/2"–1") | | 1/2"–1" | 15–25 mm (1/2"–1") |
| BK 212 | 10 CrMo 9 10 10 CrMo VNb 91 | 250 (3625) | 15–25 mm (1/2"–1") | | 1/2"–1" | 15–25 mm (1/2"–1") |
| BK 28 ASTM | A 182 F 12 | 85 (1230) | 15–25 mm (1/2"–1") | | 1/2"–1" | 15–25 mm (1/2"–1") |
| BK 29 ASTM | A 182 F 12 | 110 (1600) | 15–25 mm (1/2"–1") | | 1/2"–1" | 15–25 mm (1/2"–1") |
| BK 212 ASTM | A 182 F 22 | 250 (3625) | 15–25 mm (1/2"–1") | | 1/2"–1" | 15–25 mm (1/2"–1") |

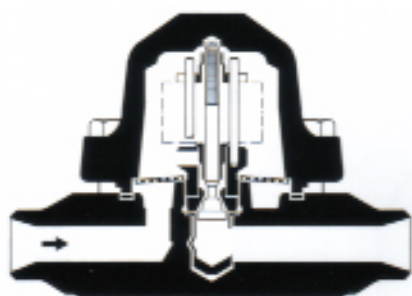

BK 28, BK 29

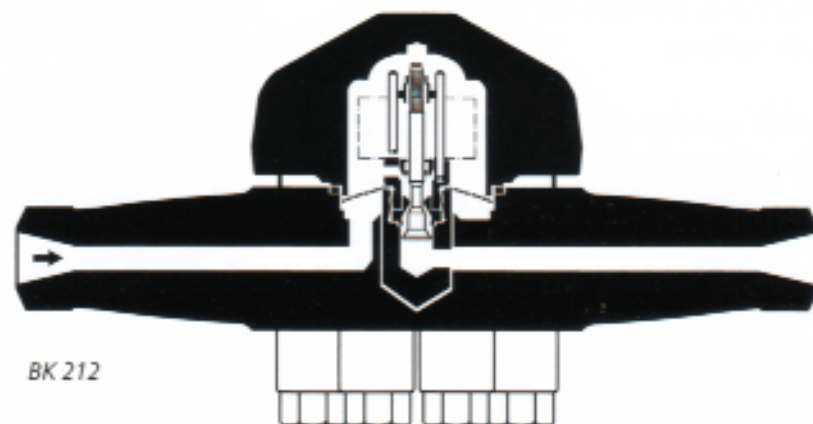

BK 212

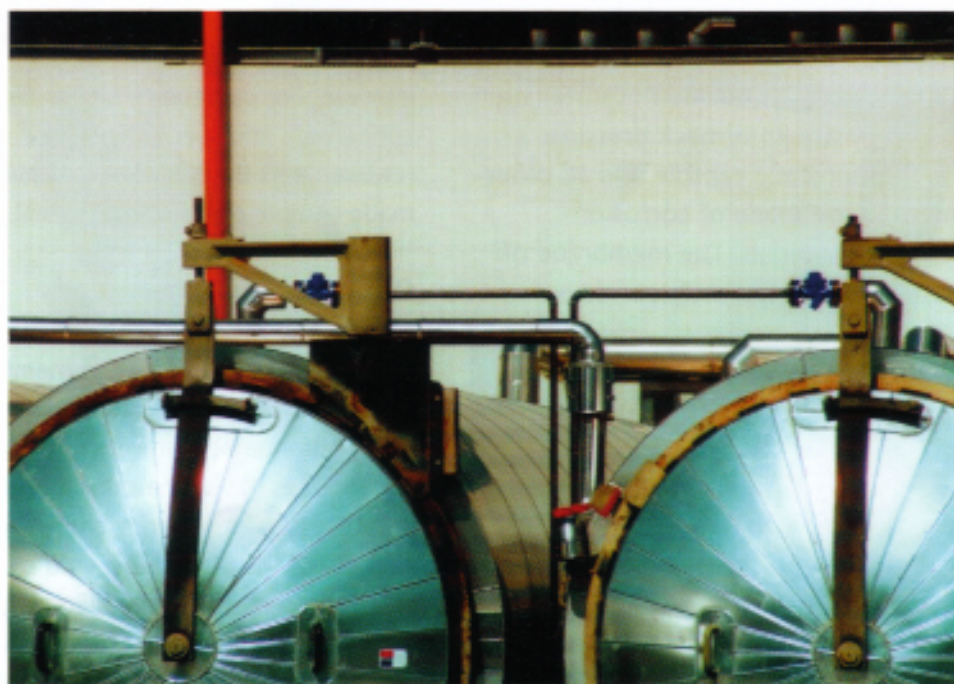
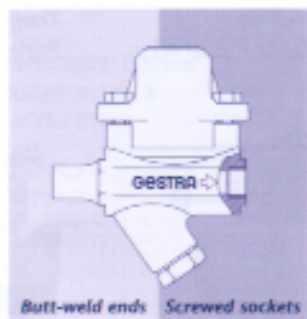
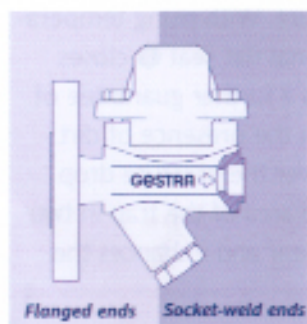

*Steam trap BK
used on autoclaves
in an insulating
block works*